

TIZ IMPLEMENTS
UCHWYTY NARZĘDZIOWE

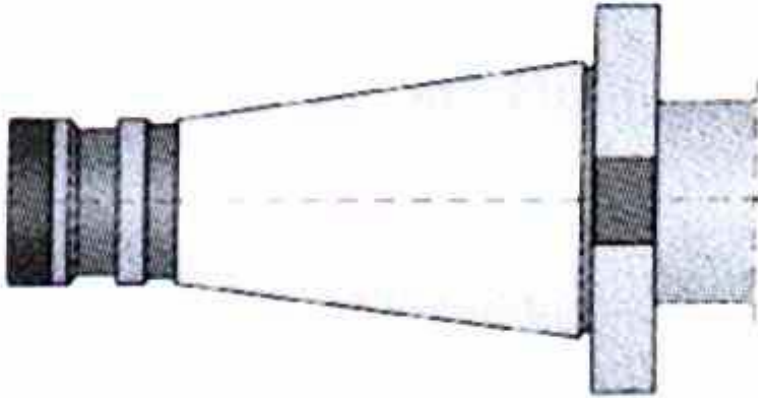

DIN 2080 (ISO)

str. 2

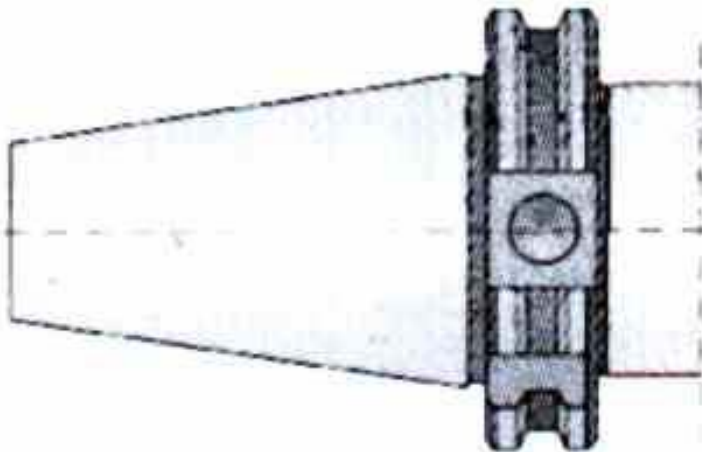

DIN 69871

str. 14

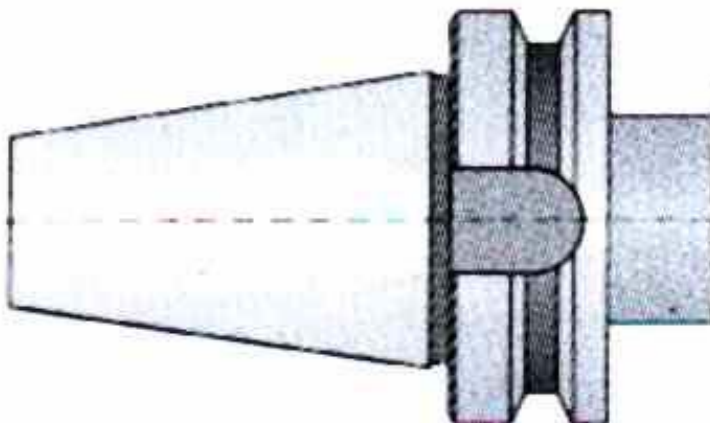

MAS 403-BT

str. 26

TIZ IMPLEMENTS

UCHWYTY NARZĘDZIOWE

DIN 2080 (ISO)

ze stożkiem 7:24

Charakterystyka techniczna wyrobów:

- Materiał: stal stopowa chromowo-manganowa
- Nawęglane na głębokość 0,7 mm
- Hartowane i precyzyjnie szlifowane
- Twardość powierzchni 58±2 HRC
- Tolerancja kąta stożka AT3

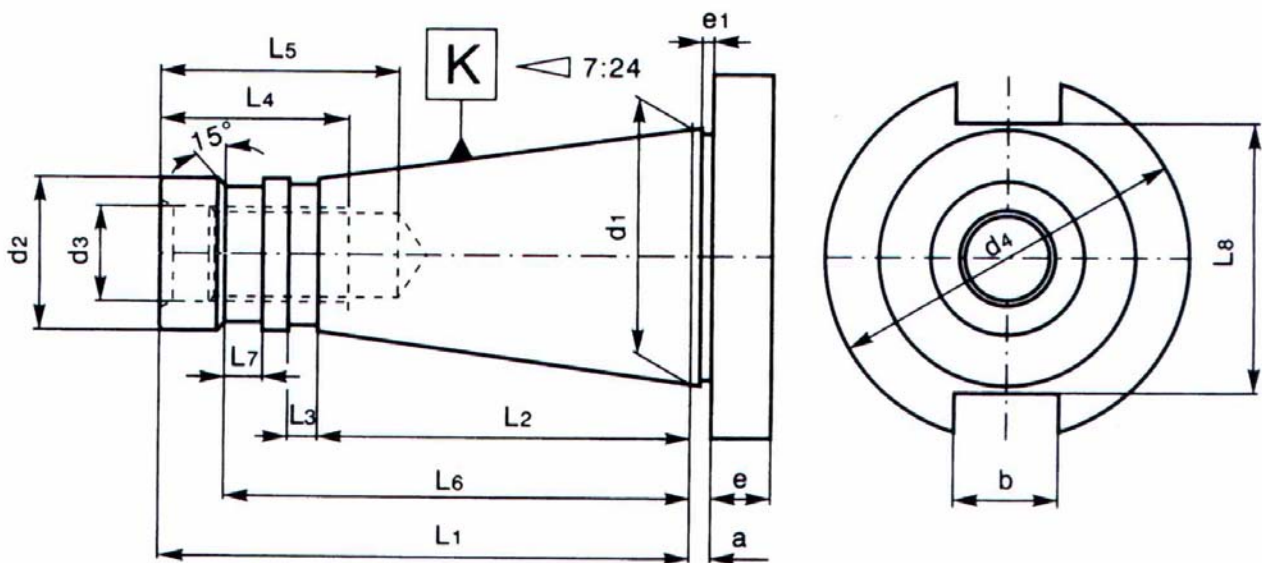

K 7:24	a±0,2	bH12	d1	d2	d3	d4	e	e1	L1	L2	L3	L4	L5	L6	L7	L8
30	1,6	16,1	31,75	17,4	M12	50,0	8	1,6	68,4	48,4	3	24	33,5	-	-	32,4
40	1,6	16,1	44,45	25,3	M16	63,0	10	1,6	93,4	65,4	5	30	42,5	82	7,0	45,0
50	3,2	25,7	69,85	39,6	M24	97,5	12	3,2	126,8	-	-	45	61,5	115	13,3	70,6

TIZ IMPLEMENTS

UCHWYTY NARZĘDZIOWE

DIN 2080 (ISO)

ze stożkiem 7:24

Charakterystyka techniczna wyrobów:

- Materiał: stal stopowa chromowo-manganowa
- Nawęglane na głębokość 0,7 mm
- Hartowane i precyzyjnie szlifowane
- Twardość powierzchni 58±2 HRC
- Tolerancja kąta stożka AT3

TYP 1655	TULEJE REDUKCYJNE do narzędzi z chwytem Morse'a	4
TYP 1676	TULEJE REDUKCYJNE do narzędzi z chwytem Morse'a z gwintem wg DIN 228-A	5
TYP 1679	TULEJE REDUKCYJNE do narzędzi z chwytem Morse'a z pletwą wg DIN 228-B	6
TYP 5370	TRZPIENIE do uchwytów wiertarskich ze stożkiem DIN 238	7
TYP 7311	TRZPIENIE FREZARSKIE ZABIERAKOWE do frezów z rowkiem zabierakowym DIN 138	8
TYP 7314	TRZPIENIE FREZARSKIE do frezów tarczowych	9
TYP 7332	TRZPIENIE FREZARSKIE UNIWERSALNE do frezów z rowkiem wpustowym lub rowkiem zabierakowym DIN 138	10
TYP 7620	OPRAWKI ZACISKOWE do narzędzi z chwytem walcowym typu WELDON DIN 1835-B	11
TYP 7616	OPRAWKI ZACISKOWE (do tulejek ER DIN 6499) do narzędzi z chwytem walcowym	12
	KOMPLETY TRZPIENI Z TULEJKAMI ZACISKOWYMI ER DIN 6499 do narzędzi z chwytem walcowym	13

TIZ IMPLEMENTS

UCHWYTY NARZĘDZIOWE

DIN 2080 (ISO)

TULEJE REDUKCYJNE
do narzędzi z chwytem Morse'a

TYP 1655

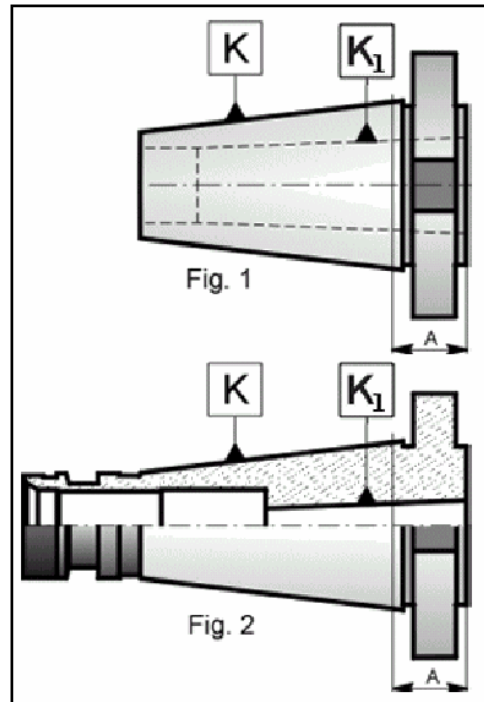

KOD ART.		K 7:24	K1 MORSE	A	FIG.	MASA kg	CENA ZŁ BEZ VAT
16550209	642 116 550 209	30	2	18	1	0.57	109,80
16550300	642 116 550 300	30	3	72	1	0.46	109,80
16555101	642 116 555 101	40	1	14	2	0.62	128,40
16555203	642 116 555 203	40	2	14	1	0.59	128,40
16555305	642 116 555 305	40	3	14	1	0.52	128,40
16555407	642 116 555 407	40	4	43	1	0.57	137,40
16555509	642 116 555 509	40	4	67	1	0.85	155,40
16556102	642 116 556 102	50	1	17	2	2.70	226,80
16556204	642 116 556 204	50	2	21	1	2.52	232,20
16556306	642 116 556 306	50	3	21	1	2.40	232,20
16556408	642 116 556 408	50	4	21	1	2.15	232,20
16556500	642 116 556 500	50	5	65	1	2.65	263,40

TIZ IMPLEMENTS

UCHWYTY NARZĘDZIOWE

DIN 2080 (ISO)

TULEJE REDUKCYJNE

do narzędzi z chwytem Morse'a z gwintem wg DIN 228-A

TYP 1676

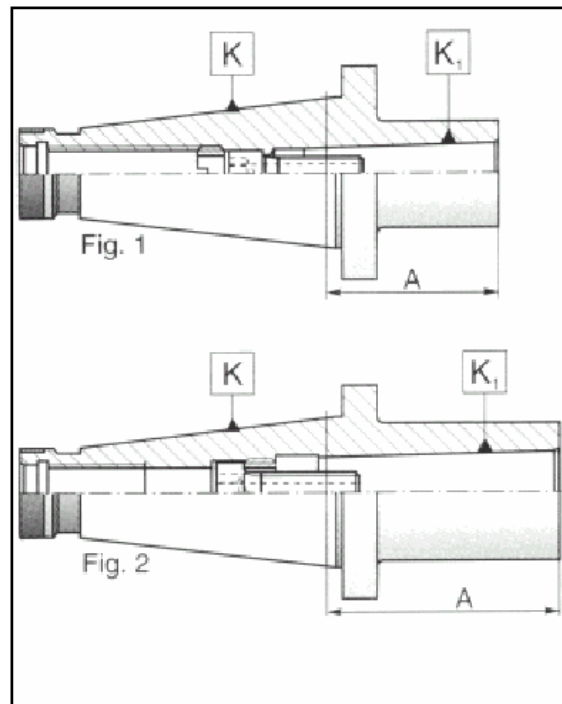

KOD ART.		K 7:24	K1 MORSE	A	FIG.	MASA kg	CENA ZŁ BEZ VAT
16761100	642 116 761 100	30	1	50	1	0.45	159,00
16761202	642 116 761 202	30	2	50	2	0.48	151,80
16761304	642 116 761 304	30	3	78	2	0.68	165,00
16760100	642 116 760 100	40	1	50	1	0.90	195,60
16760201	642 116 760 201	40	2	50	1	0.90	190,20
16760303	642 116 760 303	40	3	65	2	1.10	219,60
16760405	642 116 760 405	40	4	95	2	1.50	237,60
16760507	642 116 760 507	50	1	60	1	3.00	256,20
16760609	642 116 760 609	50	2	60	1	3.00	261,60
16760700	642 116 760 700	50	3	65	1	3.20	256,20
16760802	642 116 760 802	50	4	85	1	3.40	268,80
16760904	642 116 760 904	50	5	120	2	3.60	342,00

TIZ IMPLEMENTS

UCHWYTY NARZĘDZIOWE

DIN 2080(ISO)

TULEJE REDUKCYJNE

do narzędzi z chwytem Morse'a z pletwą wg DIN 228-B

TYP 1679

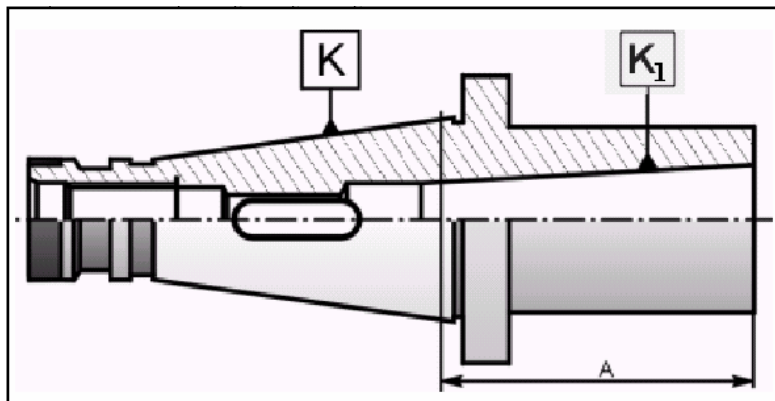

KOD ART.		K 7:24	K1 MORSE	A	MASA kg	CENA ZŁ BEZ VAT
16794915	642 116 794 915	30	1	50	0.35	118,80
16794928	642 116 794 928	30	2	50	0.40	118,80
16794930	642 116 794 930	30	3	72	0.60	127,80
16795109	642 116 795 109	40	1	50	0.90	155,40
16791105	642 116 791 105	40	1	92	1.10	183,00
16795200	642 116 795 200	40	2	50	0.90	151,80
16791207	642 116 791 207	40	2	109	1.25	192,00
16795302	642 116 795 302	40	3	65	1.00	162,60
16791309	642 116 791 309	40	3	129	1.50	201,00
16795404	642 116 795 404	40	4	95	1.50	201,00
16791400	642 116 791 400	40	4	152	2.25	246,60
16796100	642 116 796 100	50	1	45	3.00	263,40
16792106	642 116 792 106	50	1	96	3.30	281,64
16796201	642 116 796 201	50	2	60	3.00	268,80
16792208	642 116 792 208	50	2	113	3.30	312,60
16796303	642 116 796 303	50	3	65	3.20	274,20
16792300	642 116 792 300	50	3	133	3.45	331,20
16796405	642 116 796 405	50	4	70	3.20	282,00
16792401	642 116 792 401	50	4	163	3.70	373,20
16796507	642 116 796 507	50	5	105	3.20	305,40
16792503	642 116 792 503	50	5	193	3.70	428,40

TIZ IMPLEMENTS

UCHWYTY NARZĘDZIOWE DIN 2080 (ISO)

TRZPIENIE

do uchwytów wiertarskich ze stożkiem DIN 238

TYP 5370

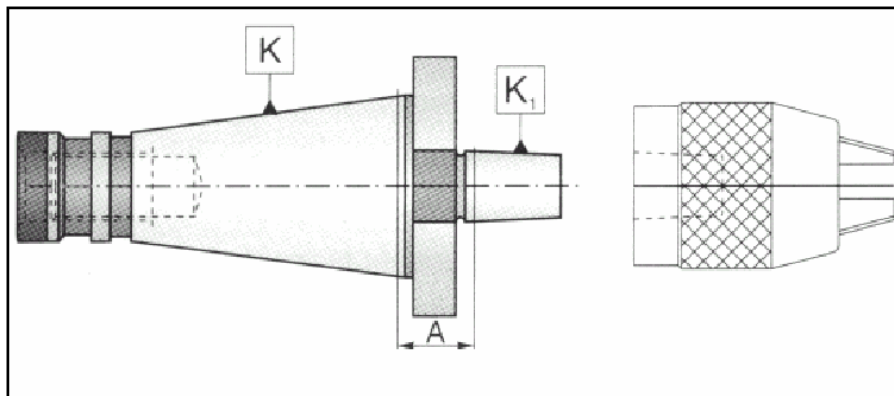

KOD ART.	K 7:24	K1 DIN	A	MASA kg	CENA ZŁ BEZ VAT	
53700103	642 153 700 103	30	B10	15	0.60	97,20
53700205	642 153 700 205	30	B12	15	0.60	97,20
53700307	642 153 700 307	30	B16	15	0.60	97,20
53701206	642 153 701 206	40	B12	17	1.00	146,40
53707100	642 153 707 100	40	B12	90	1.90	177,60
53701308	642 153 701 308	40	B16	17	1.00	146,40
53707201	642 153 707 201	40	B16	90	1.90	177,60
53701400	642 153 701 400	40	B18	17	1.00	146,40
53707303	642 153 707 303	40	B18	90	1.90	177,60
53701501	642 153 701 501	40	B22	17	1.00	146,40
53701603	642 153 701 603	40	B24	17	1.00	146,40
53702309	642 153 702 309	50	B16	20	2.70	188,40
53706109	642 153 706 109	50	B16	90	3.90	214,20
53702400	642 153 702 400	50	B18	20	2.70	188,40
53706200	642 153 706 200	50	B18	90	3.90	214,20
53702502	642 153 702 502	50	B22	20	2.70	188,40
53702604	642 153 702 604	50	B24	20	2.70	188,40

TIZ IMPLEMENTS

UCHWYTY NARZĘDZIOWE

DIN 2080 (ISO)

TRZPIENIE FREZARSKIE ZABIERAKOWE

do frezów z rowkiem zabierakowym DIN 138

TYP 7311

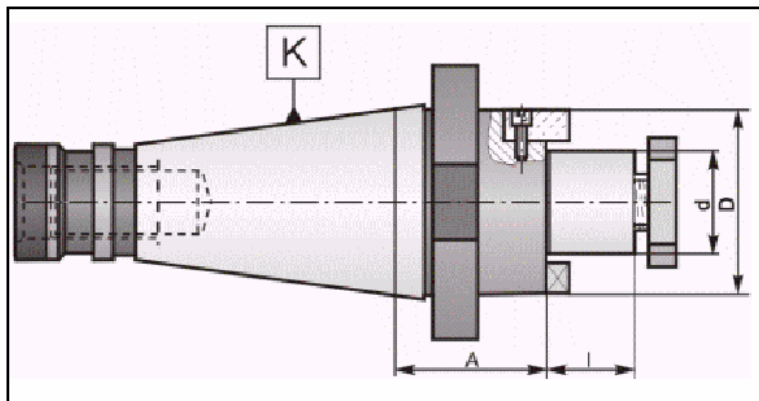

KOD ART.		K 7:24	d	A	l	D	MASA kg	CENA ZŁ BEZ VAT
73115103	642 173 115 103	30	16	35	17	32	0.50	142,80
73115129	642 173 115 129	30	22	35	19	40	0.58	142,80
73115144	642 173 115 144	30	27	35	21	48	0.63	146,40
73115157	642 173 115 157	30	32	35	24	58	0.78	168,60
73115307	642 173 115 307	40	16	37	17	32	0.95	171,84
73119107	642 173 119 107	40	16	90	17	32	1.50	208,20
73115409	642 173 115 409	40	22	37	19	40	1.00	170,40
73119209	642 173 119 209	40	22	90	19	40	1.60	210,60
73115500	642 173 115 500	40	27	37	21	48	1.15	175,80
73117502	642 173 117 502	40	27	90	21	48	1.60	214,20
73115602	642 173 115 602	40	32	37	24	58	1.28	192,00
73117604	642 173 117 604	40	32	90	24	58	1.90	228,60
73115704	642 173 115 704	40	40	37	27	70	1.85	228,60
73117706	642 173 117 706	40	40	90	27	70	2.40	256,20
73118401	642 173 118 401	50	22	40	19	40	3.00	292,80
73116400	642 173 116 400	50	22	100	19	40	3.40	320,40
73118503	642 173 118 503	50	27	40	21	48	3.25	301,80
73116501	642 173 116 501	50	27	100	21	48	3.70	338,40
73118605	642 173 118 605	50	32	40	24	58	3.40	320,40
73116603	642 173 116 603	50	32	100	24	58	4.10	338,40
73118707	642 173 118 707	50	40	40	27	70	3.60	323,40
73116705	642 173 116 705	50	40	100	27	70	4.30	338,40
73118809	642 173 118 809	50	50	40	30	90	3.95	330,00
73116807	642 173 116 807	50	50	100	30	90	4.80	372,00

TIZ IMPLEMENTS

UCHWYTY NARZĘDZIOWE DIN 2080 (ISO)

TRZPIENIE FREZARSKIE
do frezów tarczowych

TYP 7314

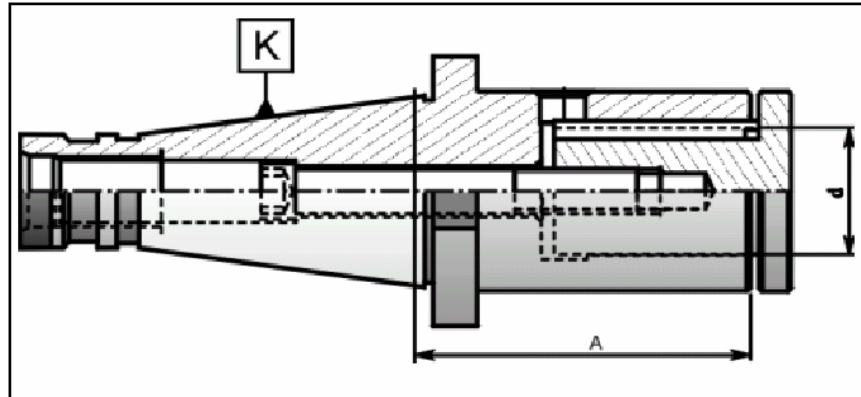

KOD ART.		K 7:24	d	A	MASA kg	CENA ZŁ BEZ VAT
73141104	642 173 141 104	40	16	70	1.40	252,00
73141603	642 173 141 603	40	16	100	1.90	282,00
73141206	642 173 141 206	40	22	70	1.50	252,00
73141705	642 173 141 705	40	22	100	2.00	276,00
73141308	642 173 141 308	40	27	70	1.60	264,00
73141807	642 173 141 807	40	27	100	2.15	294,60
73141400	642 173 141 400	40	32	70	1.90	276,00
73141909	642 173 141 909	40	32	100	2.40	301,80
73141501	642 173 141 501	40	40	70	2.35	288,00
73142003	642 173 142 003	40	40	100	3.15	320,40
73142105	642 173 142 105	50	27	75	3.10	301,80
73142400	642 173 142 400	50	27	105	3.60	342,00
73142207	642 173 142 207	50	32	75	3.70	312,72
73142502	642 173 142 502	50	32	105	4.20	355,20
73142309	642 173 142 309	50	40	75	4.40	331,20
73142604	642 173 142 604	50	40	105	5.10	367,80

TIZ IMPLEMENTS

UCHWYTY NARZĘDZIOWE DIN 2080 (ISO)

TRZPIENIE FREZARSKIE UNIWERSALNE

do frezów z rowkiem wpuścowym lub rowkiem zabierakowym DIN 138

TYP 7332

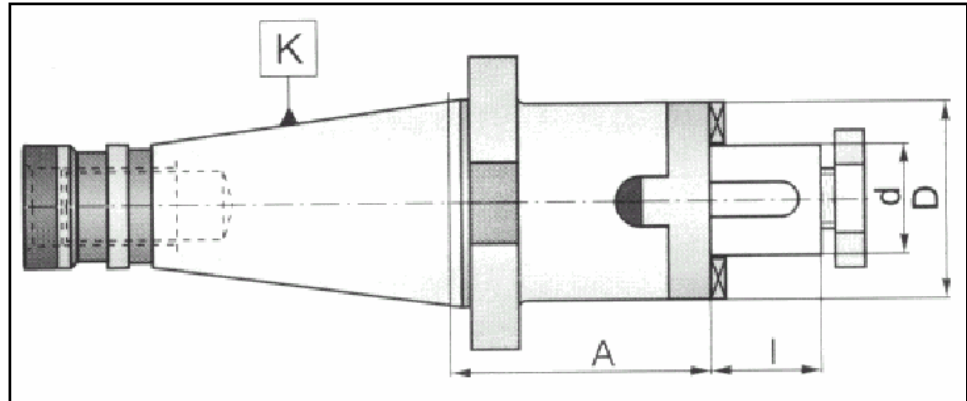

KOD ART.		K 7:24	d	A	D	MASA kg	CENA ZŁ BEZ VAT
73300207	642 173 300 207	30	16	50	32	0.65	172,20
73300309	642 173 300 309	30	22	50	40	0.85	172,20
73300400	642 173 300 400	30	27	50	48	0.95	172,20
73305507	642 173 305 507	30	32	50	58	1.10	203,40
73301208	642 173 301 208	40	16	52	32	1.10	219,60
73301300	642 173 301 300	40	22	52	40	1.30	219,60
73301401	642 173 301 401	40	27	52	48	1.60	219,60
73301503	642 173 301 503	40	32	52	58	1.85	234,00
73301605	642 173 301 605	40	40	52	70	2.05	252,00
73303200	642 173 303 200	50	16	55	32	2.98	258,00
73303301	642 173 303 301	50	22	55	40	3.05	258,00
73303403	642 173 303 403	50	27	55	48	3.25	265,20
73303505	642 173 303 505	50	32	55	58	3.50	288,00
73303607	642 173 303 607	50	40	55	70	3.85	312,60
73303709	642 173 303 709	50	50	55	90	4.05	318,60

TIZ IMPLEMENTS

UCHWYTY NARZĘDZIOWE

DIN 2080 (ISO)

OPRAWKI ZACISKKOWE

do narzędzi z chwytem walcowym typu WELDON DIN 1835-B

TYP 7620

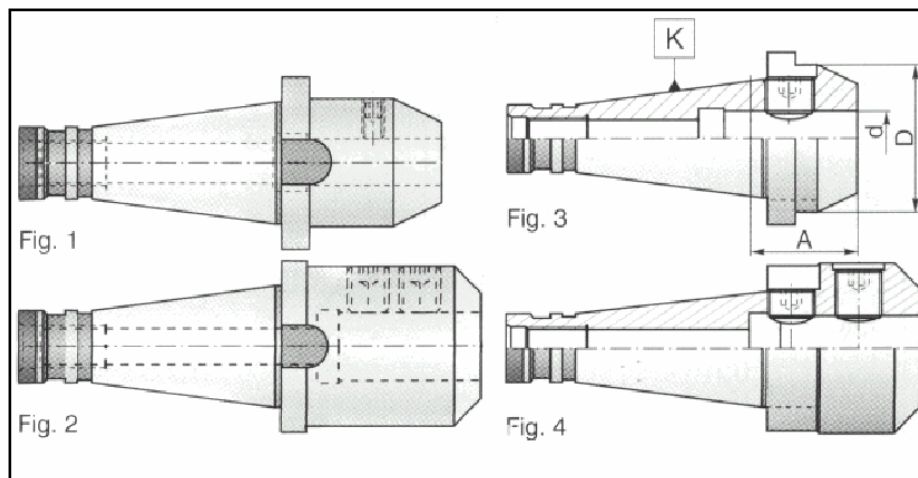

KOD ART.	K 7:24	d	A	D	FIG.	MASA kg	CENA ZŁ BEZ VAT	
76210105	642 176 210 105	30	6	40	25	1	0.50	146,40
76210207	642 176 210 207	30	8	40	28	1	0.50	137,40
76210309	642 176 210 309	30	10	40	35	1	0.60	142,80
76210400	642 176 210 400	30	12	40	42	1	0.60	142,80
76210502	642 176 210 502	30	16	50	48	1	0.90	148,20
76210604	642 176 210 604	30	20	63	52	1	1.00	163,20
76217203	642 176 217 203	40	6	25	25	3	0.70	165,00
76211106	642 176 211 106	40	6	50	25	1	0.80	171,84
76217305	642 176 217 305	40	8	25	28	3	0.70	165,00
76211208	642 176 211 208	40	8	50	28	1	0.80	171,84
76217101	642 176 217 101	40	10	27	35	3	0.80	165,00
76211300	642 176 211 300	40	10	50	35	1	0.90	171,84
76217407	642 176 217 407	40	12	29	42	3	0.90	165,00
76211401	642 176 211 401	40	12	50	42	1	1.00	171,84
76217410	642 176 217 410	40	14	30	44	3	1.15	165,00
76217422	642 176 217 422	40	14	50	44	1	1.30	171,84
76217509	642 176 217 509	40	16	31	44	3	1.25	165,00
76211503	642 176 211 503	40	16	63	48	1	1.40	174,00
76207103	642 176 207 103	40	20	35	52	3	1.25	165,00
76211605	642 176 211 605	40	20	63	52	1	1.40	174,00
76207307	642 176 207 307	40	25	60	65	4	1.80	174,00
76211707	642 176 211 707	40	25	80	63	2	2.00	183,00
76207500	642 176 207 500	40	32	70	72	2	2.10	180,00
76211809	642 176 211 809	40	32	80	72	2	2.30	219,60
76213108	642 176 213 108	50	6	63	25	1	3.30	234,00
76213200	642 176 213 200	50	8	63	28	1	3.30	234,00
76213301	642 176 213 301	50	10	63	35	1	3.60	234,00
76213403	642 176 213 403	50	12	63	42	1	3.80	234,00
76208002	642 176 208 002	50	14	63	44	1	3.90	234,00
76213505	642 176 213 505	50	16	63	48	1	4.10	234,00
76208104	642 176 208 104	50	20	36	52	3	4.00	234,00
76213607	642 176 213 607	50	20	63	52	1	4.30	234,00
76208308	642 176 208 308	50	25	60	65	4	4.70	234,00
76213709	642 176 213 709	50	25	80	65	2	5.00	234,00
76208501	642 176 208 501	50	32	70	70	4	5.00	264,00
76213800	642 176 213 800	50	32	81	70	2	5.30	274,20
76213902	642 176 213 902	50	40	91	90	2	5.60	325,80
76214109	642 176 214 109	50	50	110	97	2	6.10	367,80

TIZ IMPLEMENTS

UCHWYTY NARZĘDZIOWE DIN 2080 (ISO)

OPRAWKI ZACISKOWE (do tulejek ER DIN 6499)
do narzędzi z chwytem walcowym

TYP 7616

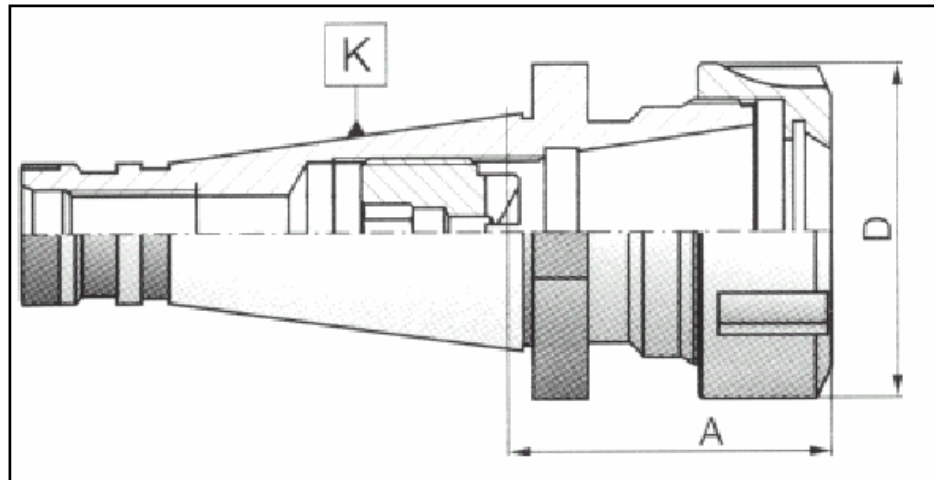

KOD ART.		K 7:24	OPRAWKA	A	ZAKRES	D	MASA kg	CENA ZŁ BEZ VAT
76160417	0642 176 160 417	30	ER16	50	2-10	32	0.60	219,60
76160623	0642 176 160 623	30	ER32	50	2-20	50	0.90	228,60
76160302	0642 176 160 302	40	ER25	60	2-16	42	1.00	247,20
76160700	0642 176 160 700	40	ER32	60	2-20	50	1.20	247,20
76163600	0642 176 163 600	40	ER32	130	2-20	50	1.80	271,20
76161303	0642 176 161 303	40	ER40	60	2-26	63	1.20	254,40
76161802	0642 176 161 802	50	ER32	70	2-20	50	3.10	296,40
76162905	0642 176 162 905	50	ER32	130	2-20	50	3.90	327,60
76162304	0642 176 162 304	50	ER40	70	2-26	63	3.20	301,80
76162600	0642 176 162 600	50	ER40	130	2-26	63	4.30	333,00
76164010		40	ER16	100	2-10	28	1,1	276,00
76164015		40	ER16	150	2-10	28	1,7	320,40
76165010		50	ER16	100	2-10	28	2,9	338,40
76165015		50	ER16	150	2-10	28	3,3	380,40

TIZ IMPLEMENTS

UCHWYTY NARZĘDZIOWE DIN 2080 (ISO)

KOMPLETY TRZPIENI Z TULEJKAMI ZACISKOWYMI ER DIN 6499
do narzędzi z chwytem walcowym



KOD ART.		K 7:24	OPRAWKA	A	ZAKRES	ILOŚĆ SZTUK	CENA ZŁ BEZ VAT
76160404	642 176 160 404	30	ER16	50	2-10	8	748,32
76160506	642 176 160 506	30	ER32	50	2-20	18	1449,00
76160109	642 176 160 109	40	ER25	60	2-16	14	1101,60
76160801	642 176 160 801	40	ER32	60	2-20	18	1467,60
76160827	642 176 160 827	40	ER32	60	3-20	8	879,60
76163407	642 176 163 407	40	ER32	130	2-20	18	1491,60
76161100	642 176 161 100	40	ER40	60	2-26	23	1975,80
76161609	642 176 161 609	50	ER32	70	2-20	18	1516,80
76161611	642 176 161 611	50	ER32	70	3-20	8	928,80
76162701	642 176 162 701	50	ER32	130	2-20	18	1548,00
76162100	642 176 162 100	50	ER40	70	2-26	23	2023,20
76162406	642 176 162 406	50	ER40	130	2-26	23	2054,40

TIZ IMPLEMENTS

UCHWYTY NARZĘDZIOWE

DIN 69871

ze stożkiem 7:24 do wymiany automatycznej

Charakterystyka techniczna wyrobów:

- Materiał: stal stopowa chromowo-manganowa
- Nawęglane na głębokość 0,7 mm
- Hartowane i precyzyjnie szlifowane
- Twardość powierzchni 58±2 HRC
- Tolerancja kąta stożka AT3

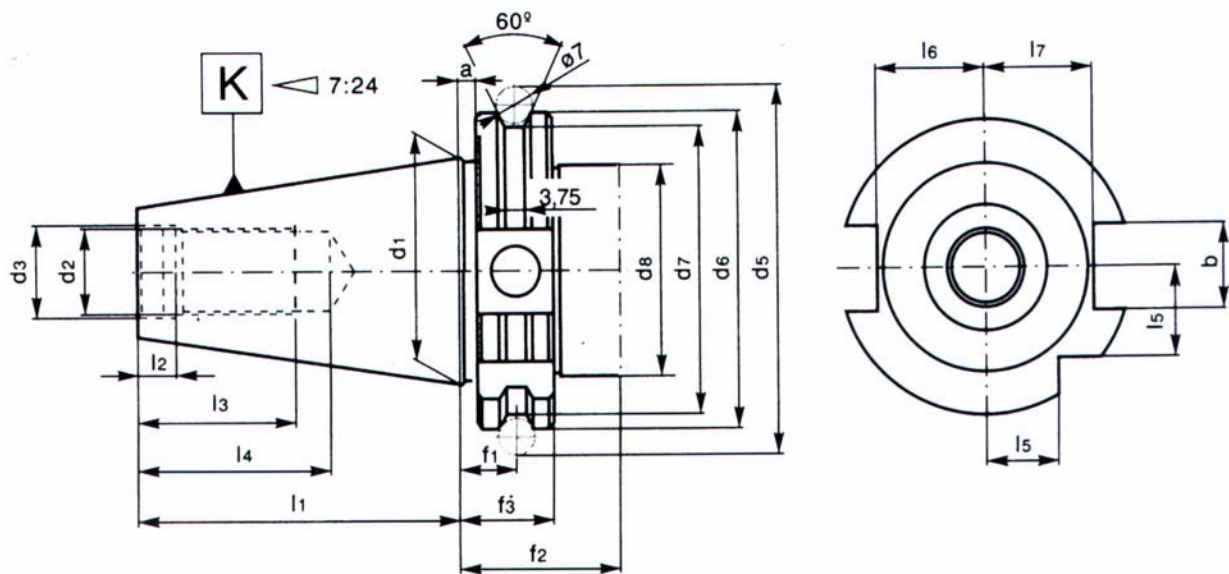

K 7:24	a	bH12	d1	d2	d3	d4	d5	d6	d7	d8 max
30	3,2	16,1	31,75	M12	13	50,0	59,30	50,00	44,30	45
40	3,2	16,1	44,45	M16	17	63,0	72,30	63,55	56,25	50
50	3,2	25,7	69,85	M24	25	97,5	107,25	97,50	91,25	80

K 7:24	f1	f2	f3	l1	l2	l3	l4	l5	l6	l7
30	11,1	35	19,1	47,80	5,5	24	33,5	15	16,4	19
40	11,1	35	19,1	68,40	8,2	32	42,5	18,5	22,8	25
50	11,1	35	19,1	101,75	11,5	47	61,5	30	35,5	37,7

TIZ IMPLEMENTS

UCHWYTY NARZĘDZIOWE

DIN 69871

ze stożkiem 7:24 do wymiany automatycznej

Charakterystyka techniczna wyrobów:

- Materiał: stal stopowa chromowo-manganowa
- Nawęglane na głębokość 0,7 mm
- Hartowane i precyzyjnie szlifowane
- Twardość powierzchni 58±2 HRC
- Tolerancja kąta stożka AT3

TYP 1682	TULEJE REDUKCYJNE do narzędzi z chwytem Morse'a	16
TYP 1695	TULEJE REDUKCYJNE do narzędzi z chwytem Morse'a z gwintem wg DIN 228-A	17
TYP 1681	TULEJE REDUKCYJNE do narzędzi z chwytem Morse'a z pletwą wg DIN 228-B	18
TYP 5374	TRZPIENIE do uchwytów wiertarskich ze stożkiem DIN 238	19
TYP 7369	TRZPIENIE FREZARSKIE ZABIERAKOWE do frezów z rowkiem zabierakowym DIN 138	20
TYP 7373	TRZPIENIE FREZARSKIE do frezów tarczowych	21
TYP 7301	TRZPIENIE FREZARSKIE UNIWERSALNE do frezów z rowkiem wpustowym lub rowkiem zabierakowym DIN 138	22
TYP 7625	OPRAWKI ZACISKOWE do narzędzi z chwytem walcowym typu WELDON DIN 1835-B	23
TYP 7617	OPRAWKI ZACISKOWE (do tulejek ER DIN 6499) do narzędzi z chwytem walcowym	24
	KOMPLETY TRZPIENI Z TULEJKAMI ZACISKOWYMI ER DIN 6499 do narzędzi z chwytem walcowym	25

TIZ IMPLEMENTS

UCHWYTY NARZĘDZIOWE

DIN 69871

TULEJE REDUKCYJNE
do narzędzi z chwytem Morse'a

TYP 1682

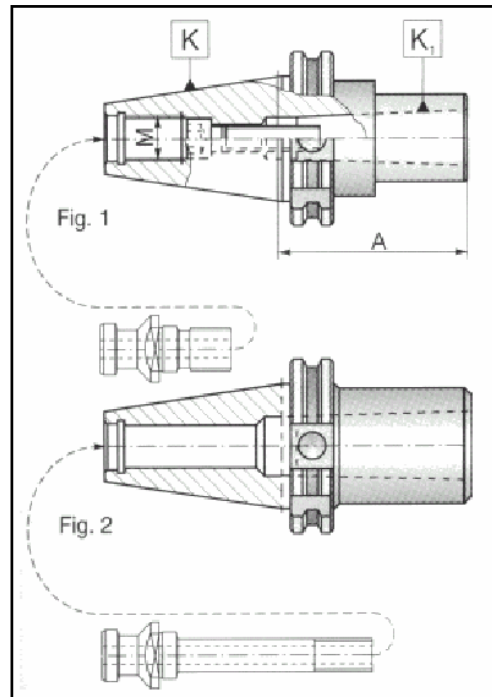

KOD ART.		K 7:24	K1 MORSE	A	M	FIG.	MASA kg	CENA ZŁ BEZ VAT
16820104	642 116 820 104	40	1	45	M16	1	0.90	177,60
16820206	642 116 820 206	40	2	60	M16	1	1.00	171,60
16820308	642 116 820 308	40	3	75	-	2	1.10	171,60
16820400	642 116 820 400	40	4	85	-	2	1.50	189,60
16821105	642 116 821 105	50	1	45	M24	1	3.00	226,80
16821207	642 116 821 207	50	2	45	M24	1	2.80	232,80
16821309	642 116 821 309	50	3	60	M24	1	3.20	232,80
16821400	642 116 821 400	50	4	75	M24	1	3.20	232,80
16821502	642 116 821 502	50	5	75	-	2	3.00	264,00

TIZ IMPLEMENTS

UCHWYTY NARZĘDZIOWE

DIN 69871

TULEJE REDUKCYJNE

do narzędzi z chwytem Morse'a z gwintem wg DIN 228-A

TYP 1695

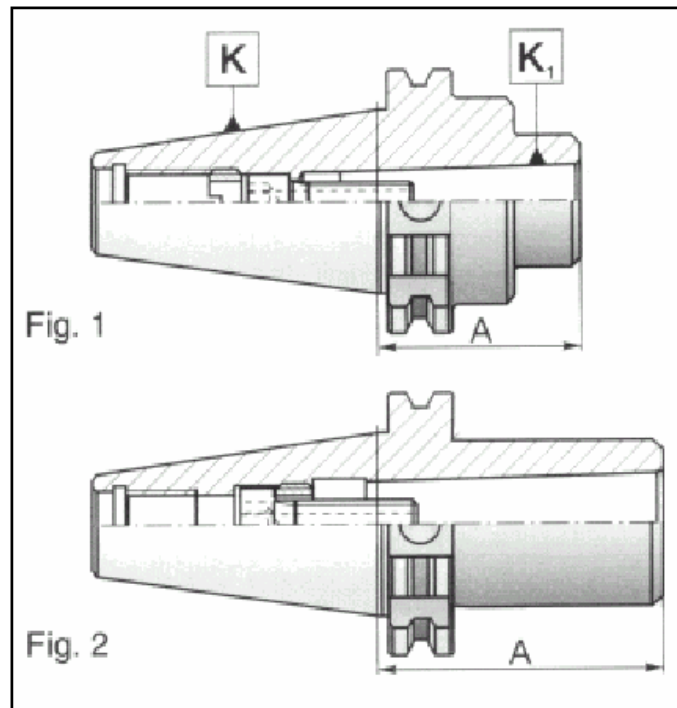

KOD ART.		K 7:24	K1 MORSE	A	FIG.	MASA kg	CENA ZŁ BEZ VAT
16952108	642 116 952 108	30	1	50	1	0.44	159,60
16952200	642 116 952 200	30	2	60	2	0.53	153,60
16952301	642 116 952 301	30	3	85	2	0.74	165,60
16950106	642 116 950 106	40	1	50	1	0.85	196,80
16950208	642 116 950 208	40	2	50	1	0.85	189,60
16950300	642 116 950 300	40	3	70	2	1.00	220,80
16950401	642 116 950 401	40	4	95	2	1.40	238,80
16951107	642 116 951 107	50	1	45	1	2.60	232,80
16951209	642 116 951 209	50	2	60	1	2.65	252,00
16951300	642 116 951 300	50	3	65	1	2.90	258,00
16951402	642 116 951 402	50	4	80	1	3.00	270,00
16951504	642 116 951 504	50	5	110	2	3.40	343,20

TIZ IMPLEMENTS

UCHWYTY NARZĘDZIOWE

DIN 69871

TULEJE REDUKCYJNE

do narzędzi z chwytem Morse'a z pletwą wg DIN 228-B

TYP 1681

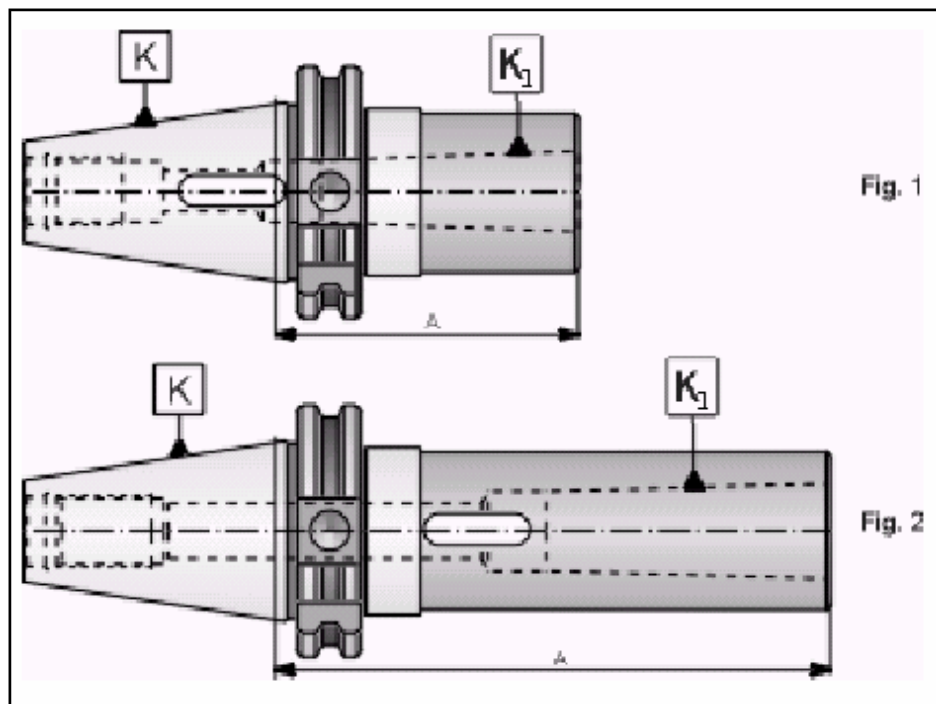

KOD ART.		K 7:24	K1 MORSE	A	FIG.	MASA kg	CENA ZŁ BEZ VAT
16810119	642 116 810 119	30	1	50	1	0.30	177,60
16810210	642 116 810 210	30	2	60	1	0.40	171,60
16810312	642 116 810 312	30	3	80	1	0.60	196,80
16810106	642 116 810 106	40	1	50	1	0.90	220,80
16810503	642 116 810 503	40	1	120	2	1.30	238,80
16810208	642 116 810 208	40	2	50	1	0.90	220,80
16810605	642 116 810 605	40	2	120	2	1.30	258,00
16810300	642 116 810 300	40	3	70	1	1.00	222,00
16810707	642 116 810 707	40	3	135	2	2.00	288,00
16810401	642 116 810 401	40	4	80	1	1.50	252,00
16810809	642 116 810 809	40	4	165	2	2.30	337,20
16811107	642 116 811 107	50	1	45	1	3.00	264,00
16811606	642 116 811 606	50	1	120	2	3.50	282,00
16811209	642 116 811 209	50	2	60	1	3.00	270,00
16811708	642 116 811 708	50	2	135	2	3.50	313,20
16811300	642 116 811 300	50	3	65	1	3.20	276,00
16811800	642 116 811 800	50	3	155	2	3.50	331,20
16811402	642 116 811 402	50	4	95	1	3.50	282,00
16811901	642 116 811 901	50	4	180	2	3.80	374,40
16811504	642 116 811 504	50	5	105	1	3.20	307,20
16812108	642 116 812 108	50	5	215	2	3.90	429,60

TIZ IMPLEMENTS

UCHWYTY NARZĘDZIOWE

DIN 69871

TRZPIENIE

do uchwytów wiertarskich ze stożkiem DIN 238

TYP 5374

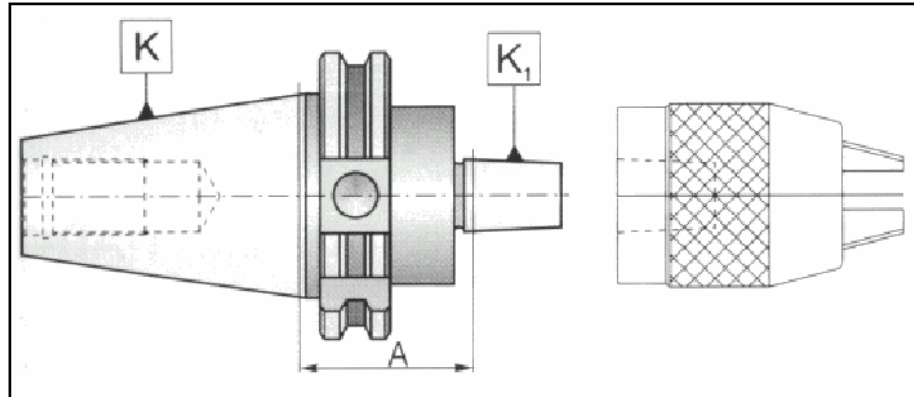

KOD ART.		K 7:24	K1 DIN	A	MASA kg	CENA ZŁ BEZ VAT
53742200	642 153 742 200	30	B12	25	0.60	112,80
53742301	642 153 742 301	30	B16	25	0.60	112,80
53740106	642 153 740 106	40	B12	40	1.10	147,60
53740605	642 153 740 605	40	B12	90	1.90	177,60
53740300	642 153 740 300	40	B16	40	1.10	140,40
53740707	642 153 740 707	40	B16	90	1.90	177,60
53740503	642 153 740 503	40	B18	40	1.10	147,60
53740809	642 153 740 809	40	B18	90	1.90	177,60
53741300	642 153 741 300	50	B16	40	2.70	189,60
53741504	642 153 741 504	50	B16	90	3.80	214,80
53741402	642 153 741 402	50	B18	40	2.70	189,60
53741606	642 153 741 606	50	B18	90	3.80	214,80

TIZ IMPLEMENTS

UCHWYTY NARZĘDZIOWE DIN 69871

TRZPIENIE FREZARSKIE ZABIERAKOWE
do frezów z rowkiem zabierakowym DIN 138

TYP 7369

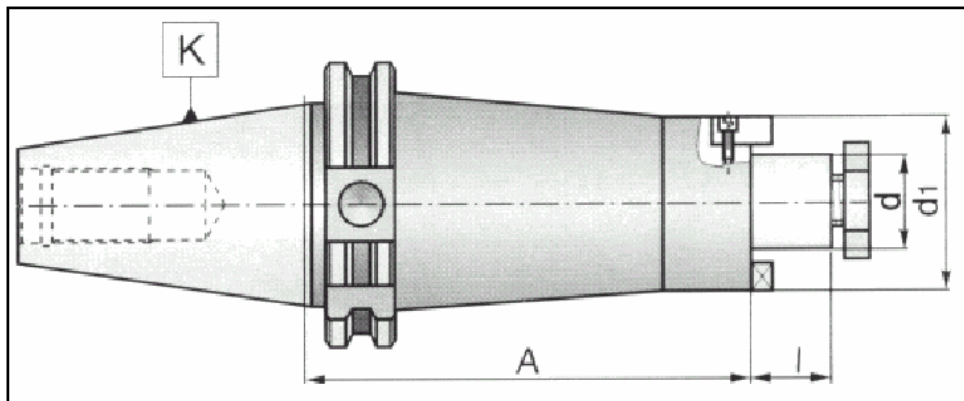

KOD ART.		K 7:24	d	A	l	d1	MASA kg	CENA ZŁ BEZ VAT
73693205	642 173 693 205	30	16	35	17	32	0.50	165,60
73693307	642 173 693 307	30	22	35	19	40	0.58	165,60
73693409	642 173 693 409	30	27	60	21	48	0.63	171,60
73693500	642 173 693 500	30	32	60	24	58	0.78	171,60
73690100	642 173 690 100	40	16	60	17	32	1.10	208,80
73690600	642 173 690 600	40	16	120	17	32	1.70	232,80
73690202	642 173 690 202	40	22	60	19	40	1.20	208,80
73690701	642 173 690 701	40	22	120	19	40	1.90	233,16
73690304	642 173 690 304	40	27	60	21	48	1.40	214,80
73690803	642 173 690 803	40	27	120	21	48	2.20	238,80
73690406	642 173 690 406	40	32	60	24	58	1.50	238,80
73690905	642 173 690 905	40	32	120	24	58	2.40	264,00
73690508	642 173 690 508	40	40	60	27	70	1.90	258,00
73691101	642 173 691 101	50	16	60	17	32	2.80	270,00
73691702	642 173 691 702	50	16	110	17	32	3.15	294,00
73691203	642 173 691 203	50	22	60	19	40	3.00	270,00
73691804	642 173 691 804	50	22	110	19	40	3.40	294,00
73691305	642 173 691 305	50	27	60	21	48	3.25	288,00
73691906	642 173 691 906	50	27	110	21	48	3.70	313,20
73691407	642 173 691 407	50	32	60	24	58	3.40	288,00
73692102	642 173 692 102	50	32	110	24	58	4.10	313,20
73691509	642 173 691 509	50	40	60	27	70	3.60	325,20
73692204	642 173 692 204	50	40	110	27	70	4.30	362,40

TIZ IMPLEMENTS

UCHWYTY NARZĘDZIOWE DIN 69871

TRZPIENIE FREZARSKIE
do frezów tarczowych

TYP 7373

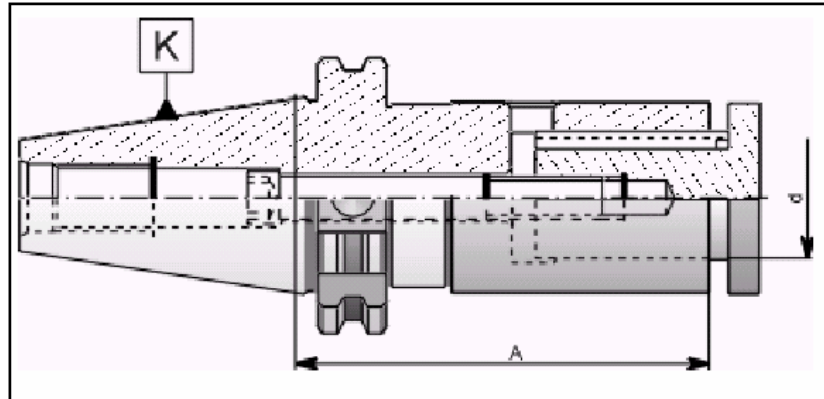

KOD ART.		K 7:24	d	A	MASA kg	CENA ZŁ BEZ VAT
73731008	642 173 731 008	40	16	95	1.50	252,00
73731100	642 173 731 100	40	16	125	2.00	282,00
73731201	642 173 731 201	40	22	95	1.60	252,00
73731303	642 173 731 303	40	22	125	2.10	282,00
73731405	642 173 731 405	40	27	95	1.70	264,00
73731507	642 173 731 507	40	27	125	2.25	294,00
73731609	642 173 731 609	40	32	95	2.00	290,40
73731700	642 173 731 700	40	32	125	2.45	300,00
73732009	642 173 732 009	50	22	100	3.10	338,40
73732100	642 173 732 100	50	22	125	3.45	366,00
73732202	642 173 732 202	50	27	100	3.30	300,00
73732304	642 173 732 304	50	27	125	3.80	343,20
73732406	642 173 732 406	50	32	100	3.90	313,20
73732508	642 173 732 508	50	32	125	4.40	355,20
73732600	642 173 732 600	50	40	100	4.60	331,20
73732701	642 173 732 701	50	40	125	5.30	368,40

TIZ IMPLEMENTS

UCHWYTY NARZĘDZIOWE DIN 69871

TRZPIENIE FREZARSKIE UNIWERSALNE

do frezów z rowkiem wpuśtowym lub rowkiem zabierakowym DIN 138

TYP 7301

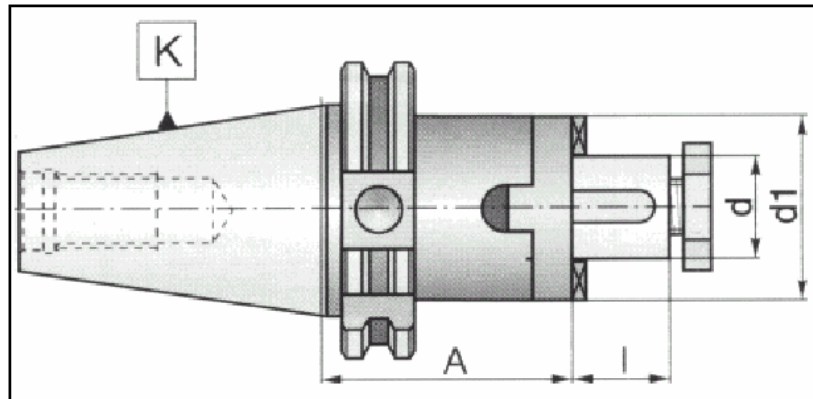

KOD ART.		K 7:24	d	A	l	d1	MASA kg	CENA ZŁ BEZ VAT
73010000	642 173 010 000	40	16	55	17	32	1.00	220,80
73010101	642 173 010 101	40	22	55	19	40	1.10	220,80
73010203	642 173 010 203	40	27	55	21	48	1.25	220,80
73010305	642 173 010 305	40	32	60	24	58	1.55	232,80
73010407	642 173 010 407	40	40	60	27	70	1.80	252,00
73010509	642 173 010 509	50	16	55	17	32	2.80	258,00
73010600	642 173 010 600	50	22	55	19	40	2.95	258,00
73010702	642 173 010 702	50	27	55	21	48	3.20	264,00
73010804	642 173 010 804	50	32	55	24	58	3.45	288,00
73010906	642 173 010 906	50	40	55	27	70	3.80	313,20
73011102	642 173 011 102	50	50	70	30	90	4.05	319,20

TIZ IMPLEMENTS

UCHWYTY NARZĘDZIOWE

DIN 69871

OPRAWKI ZACISKKOWE

do narzędzi z chwytem walcowym typu WELDON DIN 1835-B

TYP 7625

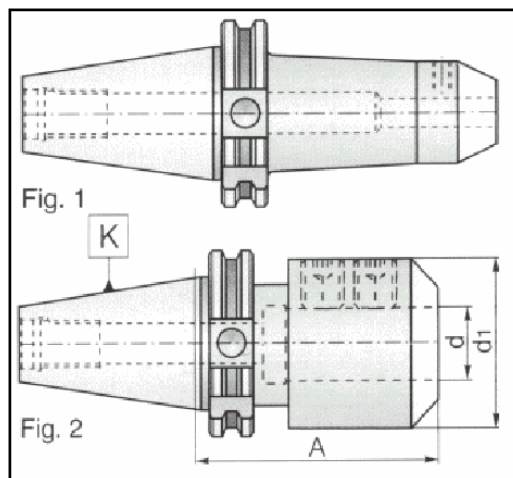

KOD ART.	K 7:24	d	A	d1	FIG.	MASA kg	CENA ZŁ BEZ VAT	
76 251 213	642 176 251 213	30	6	50	25	1	0,5	146,40
76 251 315	642 176 251 315	30	8	50	28	1	0,5	137,40
76 251 417	642 176 251 417	30	10	50	35	1	0,6	142,80
76 251 519	642 176 251 519	30	12	50	42	1	0,6	142,80
76 251 610	642 176 251 610	30	16	63	44	1	0,9	147,60
76 251 712	642 176 251 712	30	20	63	44	1	1	163,20
76 252 201	642 176 252 201	40	6	30	25	1	0,8	165,60
76 250 108	642 176 250 108	40	6	50	25	1	0,9	171,60
76 252 303	642 176 252 303	40	8	30	28	1	0,8	165,00
76 250 200	642 176 250 200	40	8	50	28	1	0,9	171,60
76 252 405	642 176 252 405	40	10	32	35	1	0,9	165,00
76 250 301	642 176 250 301	40	10	50	35	1	1	171,60
76 252 507	642 176 252 507	40	12	34	42	1	1	165,00
76 250 403	642 176 250 403	40	12	50	42	1	1,1	171,60
76 252 510	642 176 252 510	40	14	34	44	1	1,15	165,00
76 252 522	642 176 252 522	40	14	50	44	1	1,3	171,60
76 252 609	642 176 252 609	40	16	35	44	1	1,25	165,00
76 250 505	642 176 250 505	40	16	63	44,5	1	1,4	171,60
76 253 100	642 176 253 100	40	20	35	44,5	1	1,2	165,00
76 250 607	642 176 250 607	40	20	63	44,5	1	1,4	171,60
76 253 304	642 176 253 304	40	25	60	44,5	2	1,8	171,60
76 250 709	642 176 250 709	40	25	100	63	2	2	183,60
76 253 508	642 176 253 508	40	32	70	72	2	2,1	181,20
76 250 800	642 176 250 800	40	32	100	72	2	2,3	265,20
76 251 109	642 176 251 109	50	6	63	25	1	3,3	232,80
76 251 200	642 176 251 200	50	8	63	28	1	3,3	232,80
76 251 302	642 176 251 302	50	10	63	35	1	3,6	232,80
76 251 404	642 176 251 404	50	12	63	42	1	3,8	232,80
76 254 000	642 176 254 000	50	14	63	44	1	3,9	232,80
76 251 506	642 176 251 506	50	16	63	48	1	4,1	232,80
76 254 101	642 176 254 101	50	20	35	52	1	4	230,40
76 251 608	642 176 251 608	50	20	63	52	1	4,4	232,80
76 254 305	642 176 254 305	50	25	60	69,9	2	4,7	232,80
76 251 700	642 176 251 700	50	25	80	65	2	5	232,80
76 254 509	642 176 254 509	50	32	70	69,9	2	5	264,00
76 251 801	642 176 251 801	50	32	100	72	2	5,3	276,00
76 251 903	642 176 251 903	50	40	120	90	2	5,6	325,20
76 252 100	642 176 252 100	50	50	130	100	2	6,1	368,40

TIZ IMPLEMENTS

UCHWYTY NARZĘDZIOWE DIN 69871

OPRAWKI ZACISKOWE (do tulejek ER DIN 6499)

Do narzędzi z chwytem walcowym

TYP 7617

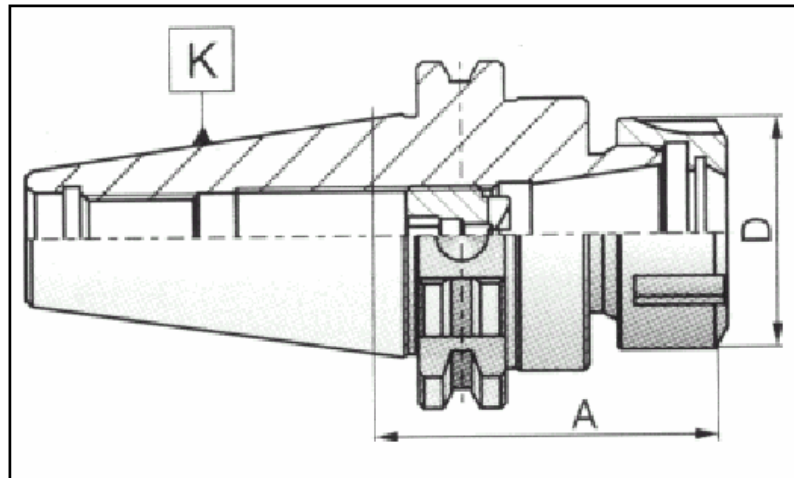

KOD ART.		K 7:24	OPRAWKA	A	ZAKRES	D	MASA kg	CENA ZŁ BEZ VAT
76170621	642 176 170 621	30	ER16	60	2-10	32	0.6	219,60
76170647	642 176 170 647	30	ER32	60	2-20	50	0.9	229,20
76170005	642 176 170 005	40	ER25	60	2-16	42	1.0	247,20
76170300	642 176 170 300	40	ER32	70	2-20	50	1.2	247,20
76171301	642 176 171 301	40	ER32	130	2-20	50	1.8	271,20
76170901	642 176 170 901	40	ER40	70	2-26	63	1.4	254,40
76171709	642 176 171 709	50	ER32	70	2-20	50	3.6	296,40
76172007	642 176 172 007	50	ER32	130	2-20	50	4.7	327,60
76172302	642 176 172 302	50	ER40	80	2-26	63	4.2	301,20
76172700	642 176 172 700	50	ER40	130	2-26	63	5.0	332,40
76174010		40	ER16	100	2-10	28	1,1	276,00
76174015		40	ER16	150	2-10	28	1,6	319,20
76175010		50	ER16	100	2-10	28	3,0	337,20
76175015		50	ER16	150	2-10	28	3,6	380,40

TIZ IMPLEMENTS

UCHWYTY NARZĘDZIOWE DIN 69871

KOMPLETY TRZPIENI Z TULEJKAMI ZACISKOWYMI ER DIN 6499
do narzędzi z chwytem walcowym



KOD ART.		K 7:24	OPRAWKA	A	ZAKRES	ILOŚĆ SZTUK	CENA ZŁ BEZ VAT
76170619	642 176 170 619	30	ER16	60	2-10	8	748,32
76170634	642 176 170 634	30	ER32	60	2-20	18	1449,00
76170107	642 176 170 107	40	ER25	60	2-16	14	1101,60
76170402	642 176 170 402	40	ER32	70	2-20	18	1467,60
76170428	642 176 170 428	40	ER32	70	3-20	8	879,60
76171108	642 176 171 108	40	ER32	130	2-20	18	1491,60
76170708	642 176 170 708	40	ER40	70	2-26	24	1975,80
76171505	642 176 171 505	50	ER32	70	2-20	18	1516,80
76171518	642 176 171 518	50	ER32	70	3-20	8	928,80
76171800	642 176 171 800	50	ER32	130	2-20	18	1548,00
76172109	642 176 172 109	50	ER40	80	2-26	24	2023,20
76172506	642 176 172 506	50	ER40	130	2-26	24	2054,40

TIZ IMPLEMENTS

UCHWYTY NARZĘDZIOWE

MAS 403-BT

ze stożkiem 7:24 do wymiany automatycznej

Charakterystyka techniczna wyrobów:

- Materiał: stal stopowa chromowo-manganowa
- Nawęglane na głębokość 0,7 mm
- Hartowane i precyzyjnie szlifowane
- Twardość powierzchni 58±2 HRC
- Tolerancja kąta stożka AT3

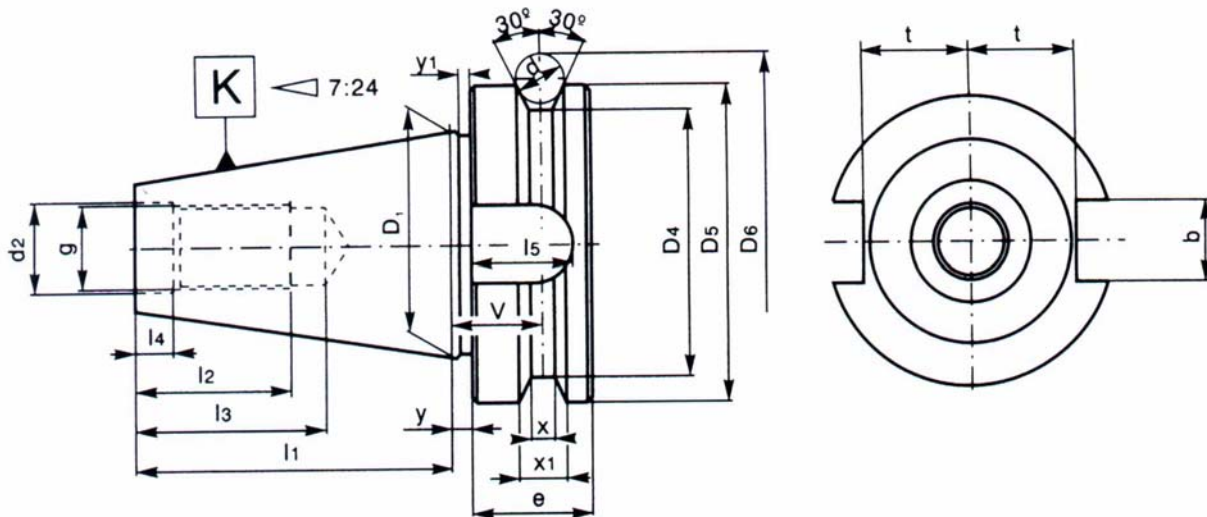

K 7:24	D1	l1	d2	g	l2	l3	l4	bH12	l5	t	D4	D5	e	v	x	x1	y	y1
30	31,75	48,4	12,5	M12	24	34	7	16,1	17	16,3	38	46	20	13,6	4	8	2	2
40	44,45	64,4	17,0	M16	30	43	9	16,1	21	22,6	53	63	25	16,6	5	10	2	2
50	69,85	101,8	25,0	M24	45	62	13	25,7	31	35,4	85	100	35	23,2	7	15	3	3

TIZ IMPLEMENTS

UCHWYTY NARZĘDZIOWE

MAS 403-BT

ze stożkiem 7:24 do wymiany automatycznej

Charakterystyka techniczna wyrobów:

- Materiał: stal stopowa chromowo-manganowa
- Nawęglane na głębokość 0,7 mm
- Hartowane i precyzyjnie szlifowane
- Twardość powierzchni 58±2 HRC
- Tolerancja kąta stożka AT3

TYP 1663	TULEJE REDUKCYJNE do narzędzi z chwytem Morse'a	28
TYP 1694	TULEJE REDUKCYJNE do narzędzi z chwytem Morse'a z gwintem wg DIN 228-A	29
TYP 1661	TULEJE REDUKCYJNE do narzędzi z chwytem Morse'a z pletwą wg DIN 228-B	30
TYP 5373	TRZPIENIE do uchwytów wiertarskich ze stożkiem DIN 238	31
TYP 7388	TRZPIENIE FREZARSKIE ZABIERAKOWE do frezów z rowkiem zabierakowym DIN 138	32
TYP 7372	TRZPIENIE FREZARSKIE do frezów tarczowych	33
TYP 7361	TRZPIENIE FREZARSKIE UNIWERSALNE do frezów z rowkiem wpustowym lub rowkiem zabierakowym DIN 138	34
TYP 7624	OPRAWKI ZACISKOWE do narzędzi z chwytem walcowym typu WELDON DIN 1835-B	35
TYP 7626	OPRAWKI ZACISKOWE (do tulejek ER DIN 6499) do narzędzi z chwytem walcowym	36
	KOMPLETY TRZPIENI Z TULEJKAMI ZACISKOWYMI ER DIN 6499 do narzędzi z chwytem walcowym	37

TIZ IMPLEMENTS

UCHWYTY NARZĘDZIOWE MAS 403-BT

TULEJE REDUKCYJNE
do narzędzi z chwytem Morse'a

TYP 1663

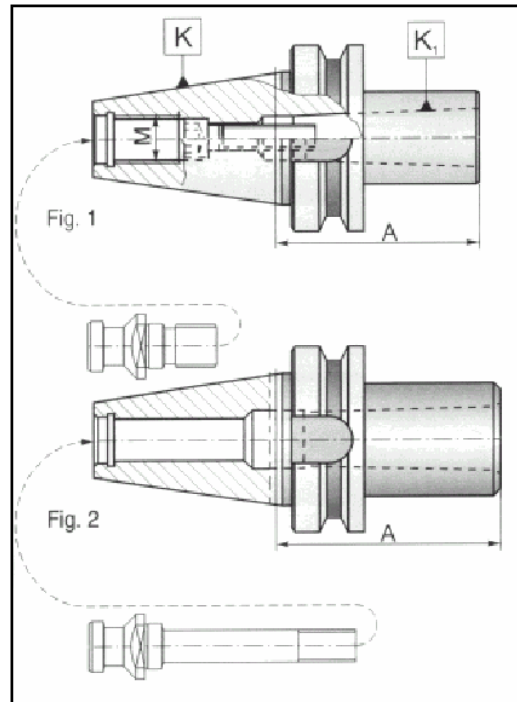

KOD ART.		K 7:24	K1 MORSE	A	FIG.	MASA kg	CENA ZŁ BEZ VAT
16635102	642 116 635 102	40	1	45	1	0.90	177,60
16635204	642 116 635 204	40	2	60	1	1.20	171,60
16635306	642 116 635 306	40	3	75	2	1.00	171,60
16635408	642 116 635 408	40	4	85	2	1.50	189,60
16636103	642 116 636 103	50	1	45	1	3.00	226,80
16636205	642 116 636 205	50	2	45	1	3.00	232,80
16636307	642 116 636 307	50	3	60	1	3.10	232,80
16636409	642 116 636 409	50	4	75	1	3.10	232,80
16636500	642 116 636 500	50	5	75	2	3.00	264,00

TIZ IMPLEMENTS

UCHWYTY NARZĘDZIOWE MAS 403-BT

TULEJE REDUKCYJNE

do narzędzi z chwytem Morse'a z gwintem wg DIN 228-A

TYP 1694

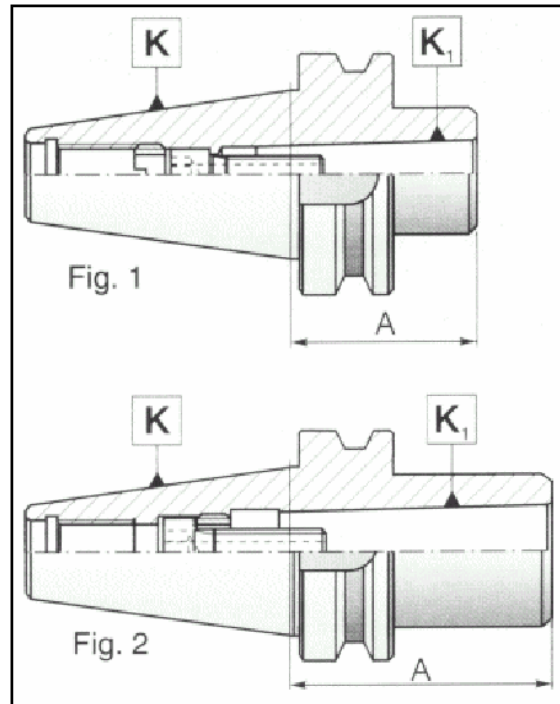

KOD ART.		K 7:24	K1 MORSE	A	FIG.	MASA kg	CENA ZŁ BEZ VAT
16942100	642 116 942 100	30	1	50	1	0.45	159,60
16942201	642 116 942 201	30	2	62	2	0.54	153,60
16942303	642 116 942 303	30	3	82	2	0.75	165,60
16940108	642 116 940 108	40	1	50	1	0.60	196,80
16940200	642 116 940 200	40	2	55	1	0.65	189,60
16940301	642 116 940 301	40	3	75	2	1.00	220,80
16940403	642 116 940 403	40	4	100	2	1.40	238,80
16941109	642 116 941 109	50	1	45	1	2.80	258,00
16941200	642 116 941 200	50	2	60	1	2.95	252,00
16941302	642 116 941 302	50	3	65	1	3.00	258,00
16941404	642 116 941 404	50	4	80	1	3.10	270,00
16941506	642 116 941 506	50	5	110	2	3.40	343,20

TIZ IMPLEMENTS

UCHWYTY NARZĘDZIOWE MAS 430-BT

TULEJE REDUKCYJNE

do narzędzi z chwytem Morse'a z pletwą wg DIN 228-B

TYP 1661

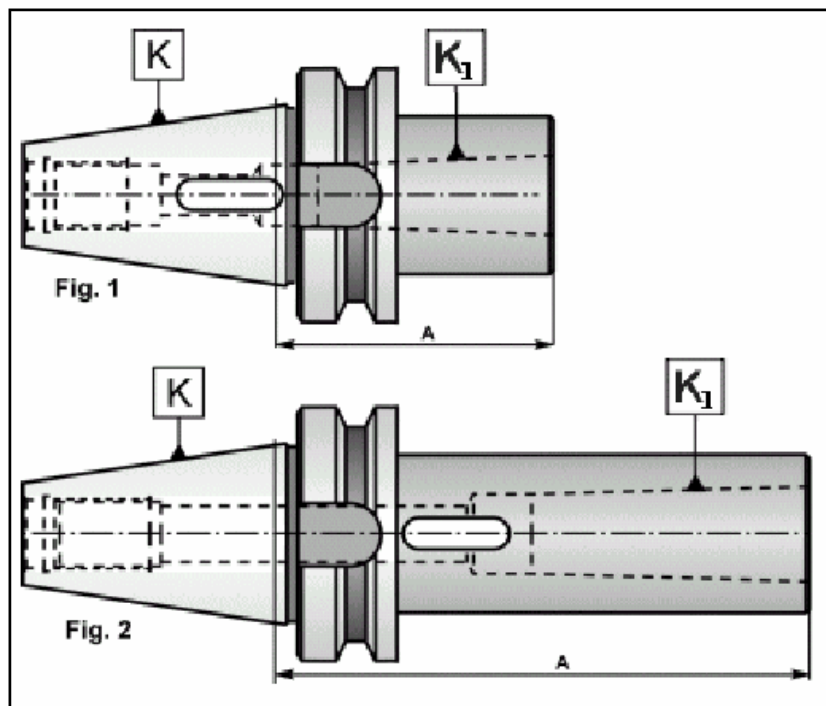

KOD ART.	K 7:24	K1 MORSE	A	FIG.	MASA kg	CENA ZŁ BEZ VAT	
16617108	642 116 617 108	30	1	50	1	0.30	177,60
16617200	642 116 617 200	30	2	60	1	0.40	171,60
16617301	642 116 617 301	30	3	79	1	0.60	196,80
16613104	642 116 613 104	40	1	50	1	0.90	220,80
16613501	642 116 613 501	40	1	120	2	1.30	238,80
16613206	642 116 613 206	40	2	50	1	1.20	220,80
16613603	642 116 613 603	40	2	120	2	1.40	258,00
16613308	642 116 613 308	40	3	70	1	1.00	226,80
16613705	642 116 613 705	40	3	135	2	2.00	288,00
16613400	642 116 613 400	40	4	95	1	1.50	252,00
16613807	642 116 613 807	40	4	165	2	2.30	337,20
16614105	642 116 614 105	50	1	45	1	3.00	264,00
16614604	642 116 614 604	50	1	120	2	3.50	282,00
16614207	642 116 614 207	50	2	60	1	3.00	270,00
16614706	642 116 614 706	50	2	135	2	3.50	313,20
16614309	642 116 614 309	50	3	65	1	3.20	276,00
16614808	642 116 614 808	50	3	155	2	3.50	331,20
16614400	642 116 614 400	50	4	95	1	3.30	282,00
16614900	642 116 614 900	50	4	180	2	3.80	374,40
16614502	642 116 614 502	50	5	105	2	3.20	307,20
16615106	642 116 615 106	50	5	215	2	3.90	429,60

TIZ IMPLEMENTS

UCHWYTY NARZĘDZIOWE MAS 430-BT

TRZPIENIE

do uchwytów wiertarskich ze stożkiem DIN 238

TYP 5373

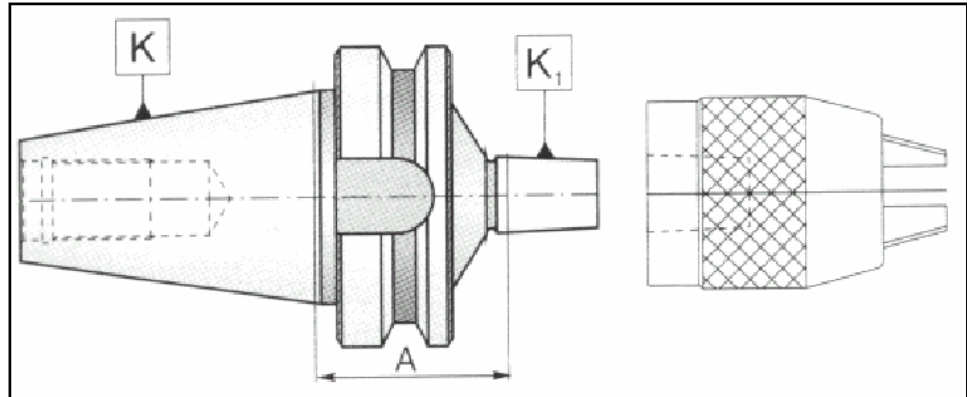

KOD ART.		K 7:24	K1 DIN	A	MASA kg	CENA ZŁ BEZ VAT
53736103	642 153 736 103	30	B12	30	0.60	117,60
53736205	642 153 736 205	30	B16	30	0.60	117,60
53733100	642 153 733 100	40	B12	40	1.20	147,60
53733600	642 153 733 600	40	B12	90	2.00	177,60
53733304	642 153 733 304	40	B16	42	1.20	147,60
53733701	642 153 733 701	40	B16	90	2.00	177,60
53733508	642 153 733 508	40	B18	42	1.20	147,60
53733803	642 153 733 803	40	B18	90	2.00	177,60
53734305	642 153 734 305	50	B16	45	2.70	189,60
53735306	642 153 735 306	50	B16	90	3.90	214,80
53734509	642 153 734 509	50	B18	45	2.70	189,60
53735500	642 153 735 500	50	B18	90	3.90	214,80

TIZ IMPLEMENTS

UCHWYTY NARZĘDZIOWE MAS 430-BT

TRZPIENIE FREZARSKIE ZABIERAKOWE
do frezów z rowkiem zabierakowym DIN 138

TYP 7388

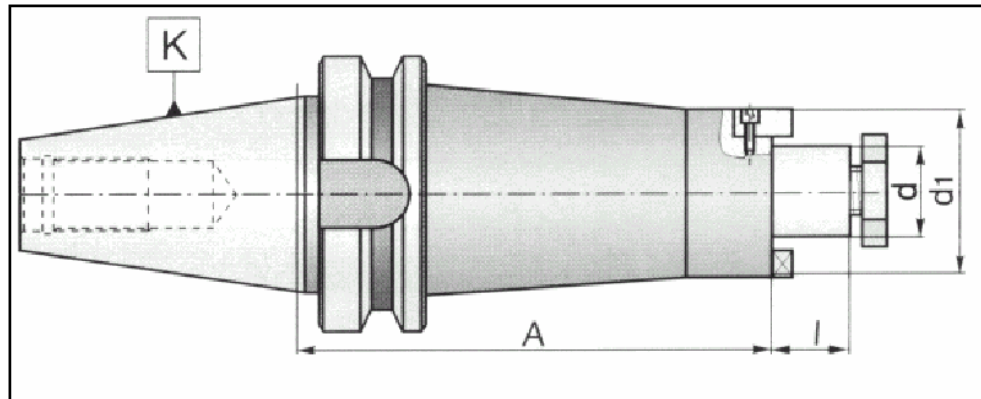

KOD ART.		K 7:24	d	A	l	d1	MASA kg	CENA ZŁ BEZ VAT
73883100	642 173 883 100	30	16	43	17	32	0.50	165,60
73883201	642 173 883 201	30	22	43	19	40	0.58	165,60
73883303	642 173 883 303	30	27	43	21	48	0.63	171,60
73883405	642 173 883 405	30	32	45	24	58	0.78	171,60
73880107	642 173 880 107	40	16	52	17	32	1.10	208,80
73880606	642 173 880 606	40	16	120	17	32	1.70	232,80
73880209	642 173 880 209	40	22	52	19	40	1.20	208,80
73880708	642 173 880 708	40	22	120	19	40	1.90	232,80
73880300	642 173 880 300	40	27	52	21	48	1.40	214,80
73880800	642 173 880 800	40	27	120	21	48	2.20	238,80
73880402	642 173 880 402	40	32	52	24	58	1.50	238,80
73880901	642 173 880 901	40	32	120	24	58	2.40	264,00
73880504	642 173 880 504	40	40	60	27	70	1.90	258,00
73881108	642 173 881 108	50	16	65	17	32	2.80	270,00
73881709	642 173 881 709	50	16	110	17	32	3.15	294,00
73881200	642 173 881 200	50	22	65	19	40	3.00	270,00
73881800	642 173 881 800	50	22	110	19	40	3.40	294,00
73881301	642 173 881 301	50	27	65	21	48	3.25	288,00
73881902	642 173 881 902	50	27	110	21	48	3.40	313,20
73881403	642 173 881 403	50	32	65	24	58	3.40	288,00
73882109	642 173 882 109	50	32	110	24	58	4.10	313,20
73881505	642 173 881 505	50	40	78	27	70	3.60	325,20
73882200	642 173 882 200	50	40	110	27	70	4.30	362,40
73881607	642 173 881 607	50	50	78	30	90	4.00	408,00

TIZ IMPLEMENTS

UCHWYTY NARZĘDZIOWE MAS 403-BT

TRZPIENIE FREZARSKIE
do frezów tarczowych

TYP 7372

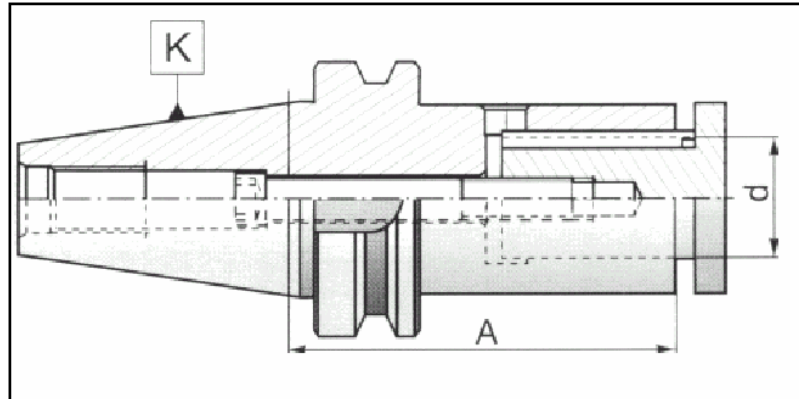

KOD ART.		K 7:24	d	A	MASA kg	CENA ZŁ BEZ VAT
73721000	642 173 721 000	40	16	95	1.50	252,00
73721101	642 173 721 101	40	16	125	2.00	282,00
73721203	642 173 721 203	40	22	95	1.60	252,00
73721305	642 173 721 305	40	22	125	2.10	282,00
73721407	642 173 721 407	40	27	95	1.70	264,00
73721509	642 173 721 509	40	27	125	2.25	294,00
73721600	642 173 721 600	40	32	95	2.00	276,00
73721702	642 173 721 702	40	32	125	2.45	300,00
73722000	642 173 722 000	50	22	100	3.10	300,00
73722102	642 173 722 102	50	22	125	3.45	343,20
73722204	642 173 722 204	50	27	100	3.30	300,00
73722306	642 173 722 306	50	27	125	3.80	343,20
73722408	642 173 722 408	50	32	100	3.90	313,20
73722500	642 173 722 500	50	32	125	4.40	355,20
73722601	642 173 722 601	50	40	100	4.60	331,20
73722703	642 173 722 703	50	40	125	5.30	368,40

TIZ IMPLEMENTS

UCHWYTY NARZĘDZIOWE MAS 430-BT

TRZPIENIE FREZARSKIE UNIWERSALNE

do frezów z rowkiem wpuśowym lub rowkiem zabierakowym DIN 138

TYP 7361

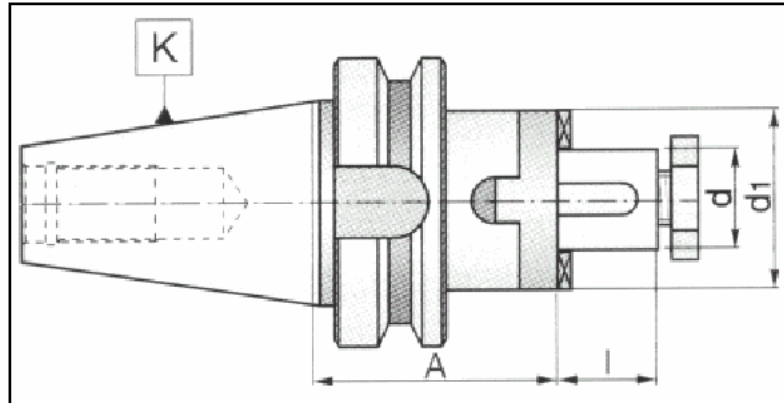

KOD ART.		K 7:24	d	A	l	D	MASA kg	CENA ZŁ BEZ VAT
73617000	642 173 617 000	40	16	55	17	32	1.20	220,80
73617101	642 173 617 101	40	22	55	19	40	1.40	220,80
73617203	642 173 617 203	40	27	55	21	48	1.70	220,80
73617305	642 173 617 305	40	32	60	24	58	1.95	232,80
73617407	642 173 617 407	40	40	60	27	70	2.15	252,00
73617509	642 173 617 509	50	16	70	17	32	3.00	258,00
73617600	642 173 617 600	50	22	70	19	40	3.15	258,00
73617702	642 173 617 702	50	27	70	21	48	3.35	264,00
73617804	642 173 617 804	50	32	70	24	58	3.60	288,00
73617906	642 173 617 906	50	40	70	27	70	3.95	313,20
73618000	642 173 618 000	50	50	70	30	90	4.15	319,20

TIZ IMPLEMENTS

UCHWYTY NARZĘDZIOWE MAS 430-BT

OPRAWKI ZACISKOWE

do narzędzi z chwytem walcowym typu WELDON DIN 1835-B

TYP 7624

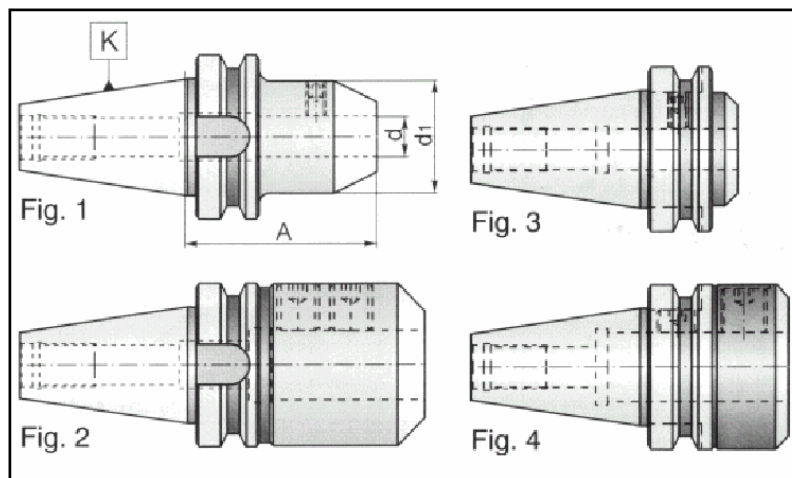

KOD ART.	K 7:24	d	A	D	FIG.	MASA kg	CENA ZŁ BEZ VAT	
76242203	642 176 242 203	30	6	50	25	1	0.50	146,40
76242305	642 176 242 305	30	8	50	28	1	0.50	137,40
76242407	642 176 242 407	30	10	50	35	1	0.60	142,80
76242509	642 176 242 509	30	12	50	42	1	0.60	142,80
76242600	642 176 242 600	30	16	63	48	1	0.90	147,60
76242702	642 176 242 702	30	20	63	52	1	1.00	163,20
76243204	642 176 243 204	40	6	35	25	3	0.80	165,60
76240100	642 176 240 100	40	6	50	25	1	0.90	171,60
76243306	642 176 243 306	40	8	35	28	3	0.80	165,00
76240201	642 176 240 201	40	8	50	28	1	0.90	171,60
76243408	642 176 243 408	40	10	37	35	3	0.90	165,00
76240303	642 176 240 303	40	10	63	35	1	1.00	171,60
76243500	642 176 243 500	40	12	37	42	3	1.00	165,00
76240405	642 176 240 405	40	12	63	42	1	1.10	171,60
76243512	642 176 243 512	40	14	37	44	3	1.15	165,00
76243525	642 176 243 525	40	14	63	44	1	1.30	171,60
76243601	642 176 243 601	40	16	37	48	3	1.25	165,00
76240507	642 176 240 507	40	16	63	48	1	1.40	171,60
76243703	642 176 243 703	40	20	37	50	3	1.20	165,00
76240609	642 176 240 609	40	20	63	50	1	1.40	171,60
76243805	642 176 243 805	40	25	60	63	4	1.80	171,60
76240700	642 176 240 700	40	25	90	63	2	2.00	183,60
76243907	642 176 243 907	40	32	65	72	4	2.10	181,20
76240802	642 176 240 802	40	32	100	72	2	2.30	265,20
76241100	642 176 241 100	50	6	63	25	1	3.30	232,80
76241202	642 176 241 202	50	8	63	28	1	3.30	232,80
76241304	642 176 241 304	50	10	63	35	1	3.60	232,80
76241406	642 176 241 406	50	12	80	42	1	3.80	232,80
76244307	642 176 244 307	50	14	80	44	1	3.90	232,80
76241508	642 176 241 508	50	16	80	48	1	4.10	232,80
76244409	642 176 244 409	50	20	40	52	3	4.00	230,40
76241600	642 176 241 600	50	20	80	52	1	4.30	232,80
76244500	642 176 244 500	50	25	60	63	4	4.70	232,80
76241701	642 176 241 701	50	25	100	63	2	5.00	232,80
76244602	642 176 244 602	50	32	70	72	4	5.00	
76241803	642 176 241 803	50	32	105	72	2	5.30	276,00
76241905	642 176 241 905	50	40	120	90	2	5.60	325,20
76242101	642 176 242 101	50	50	130	100	2	6.10	368,40

TIZ IMPLEMENTS

UCHWYTY NARZĘDZIOWE MAS 430-BT

OPRAWKI ZACISKOWE (do tulejek ER DIN 6499)
do narzędzi z chwytem walcowym

TYP 7626

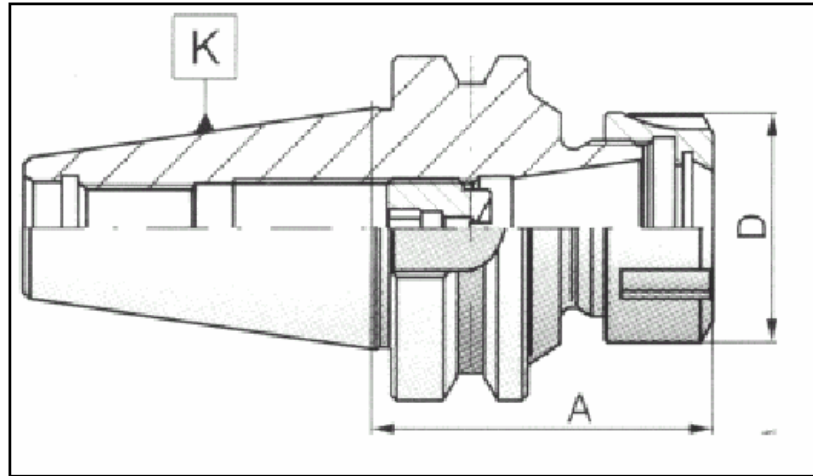

KOD ART.		K 7:24	OPRAWKA	A	ZAKRES	D	MASA kg	CENA ZŁ BEZ VAT
76263302	642 176 263 302	30	ER16	60	2-10	32	0.6	219,60
76263007	642 176 263 007	30	ER32	60	2-20	50	0.9	229,20
76260004	642 176 260 004	40	ER25	60	2-16	42	1.3	247,20
76260300	642 176 260 300	40	ER32	70	2-20	50	1.6	247,20
76261300	642 176 261 300	40	ER32	130	2-20	50	1.8	271,20
76260900	642 176 260 900	40	ER40	70	2-26	63	1.9	254,40
76261402	642 176 261 402	50	ER32	70	2-20	50	3.5	296,40
76261901	642 176 261 901	50	ER32	130	2-20	50	4.3	327,60
76262006	642 176 262 006	50	ER40	80	2-26	63	4.1	301,20
76262505	642 176 262 505	50	ER40	130	2-26	63	4.3	332,40
76264010		40	ER16	100	2-10	28	1,1	276,00
76264015		40	ER16	150	2-10	28	1,7	319,20
76265010		50	ER16	100	2-10	28	2,9	337,20
76265015		50	ER16	150	2-10	28	3,3	378,00

TIZ IMPLEMENTS

UCHWYTY NARZĘDZIOWE MAS 430-BT

KOMPLETY TRZPIENI Z TULEJKAMI ZACISKOWYMI ER DIN 6499
do narzędzi z chwytem walcowym



KOD ART.		K 7:24	OPRAWKA	A	ZAKRES	ILOŚĆ SZTUK	CENA ZŁ BEZ VAT
76263404	642 176 263 404	30	ER16	60	2-10	8	748,32
76263109	642 176 263 109	30	ER32	60	2-20	18	1449,00
76260106	642 176 260 106	40	ER25	60	2-16	14	1101,60
76260401	642 176 260 401	40	ER32	70	2-20	18	1467,60
76260516	642 176 260 516	40	ER32	70	2-30	8	879,60
76261107	642 176 261 107	40	ER32	130	2-20	18	1491,60
76260707	642 176 260 707	40	ER40	70	2-26	24	1975,80
76261504	642 176 261 504	50	ER32	70	2-20	18	1516,80
76261517	642 176 261 517	50	ER32	70	2-30	8	928,80
76261708	642 176 261 708	50	ER32	130	2-20	18	1548,00
76262108	642 176 262 108	50	ER40	80	2-26	24	2023,20
76262301	642 176 262 301	50	ER40	130	2-26	24	2054,40